

Besinnungsweg in Maxhütte-Haidhof

Initiator: Prof. Dr. Heribert Popp

Station: Arbeit – Familie

Gestaltungsvorschlag: BSZ-SAD

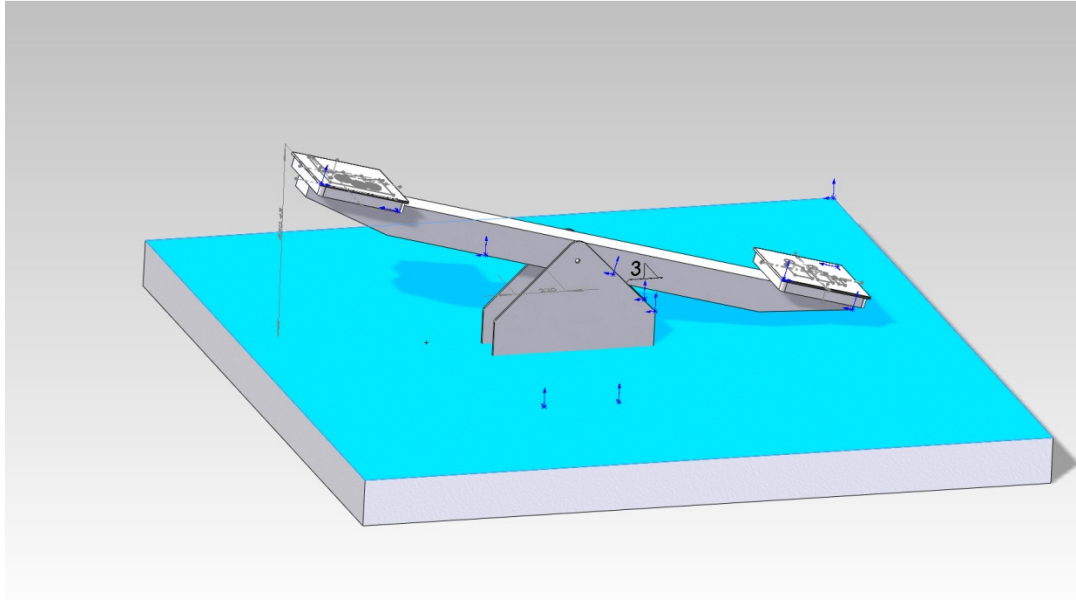

Gestell:

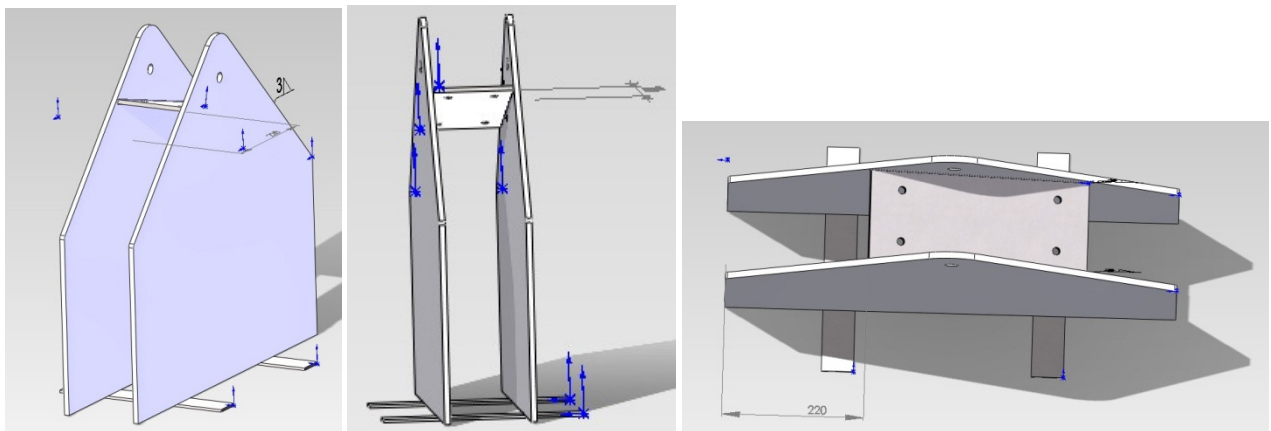

Piktogramme:

Arbeit

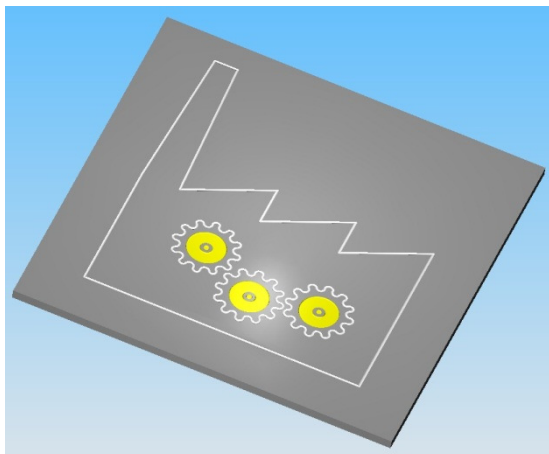

Familie

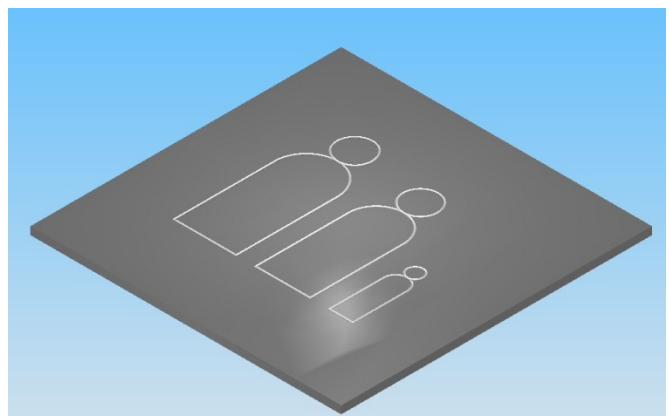

Stückliste für Gestell

Pos.	Bezeichnung	Material	Anzahl	Bemerkung
01	Wange	1.4301	2	
02	Balkenlager	1.4301	1	Auch t=10 möglich
03	Anker	1.4301	2	Auch t=8 oder t=10 möglich
04	Anker-Wippenende	1.4301	1	Auch t= 10 möglich

Detailmaße: siehe Konstruktionszeichnungen

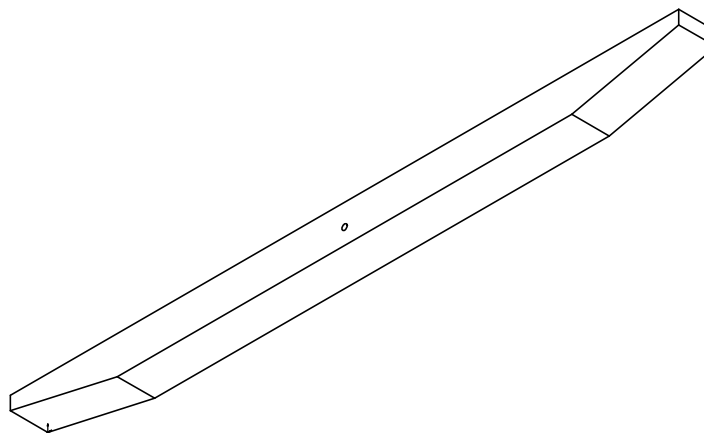
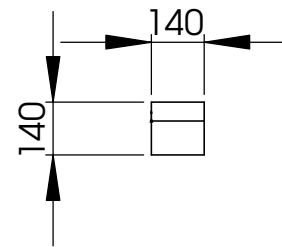
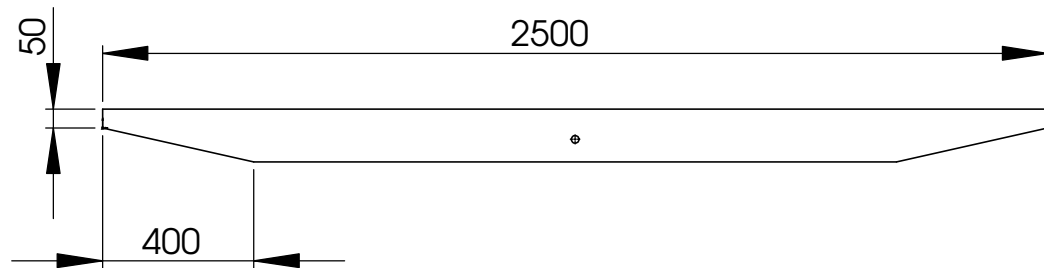

				Maßstab: 1:20		Gewicht:	
				(Werkstoff, Halbzeug)			
				Material			
				Datum		NAME	
				Gez. 22.03.2012		Autor	
				Klasse: Klasse			
				Berufliches Schulzentrum		Zeichnungsnummer:	
				Oskar-von-Miller			
				Schwandorf			
Status		Änderungen		Datum		Name	
						A4	
						Bl. 1v.1	

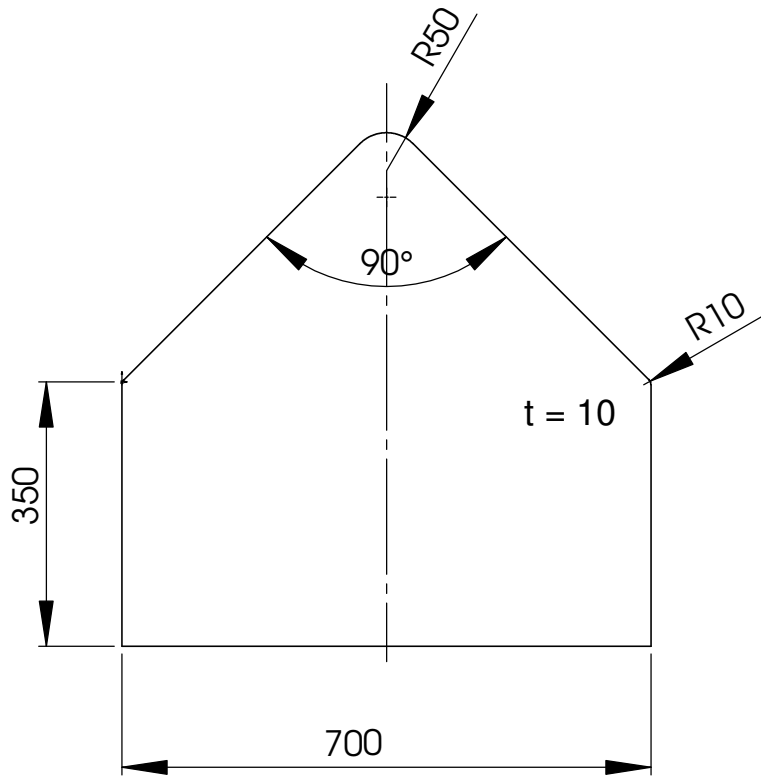

				Maßstab: 1:10		Gewicht:	
				(Werkstoff, Halbzeug)			
				Material			
				Datum		NAME	
				Gez. 29.03.2012		Autor	
				Klasse: Klasse			
				Berufliches Schulzentrum		Zeichnungsnummer:	
				Oskar-von-Miller			
				Schwandorf			
Status		Änderungen		Datum		Name	
						A4	
						Bl. 1v.1	

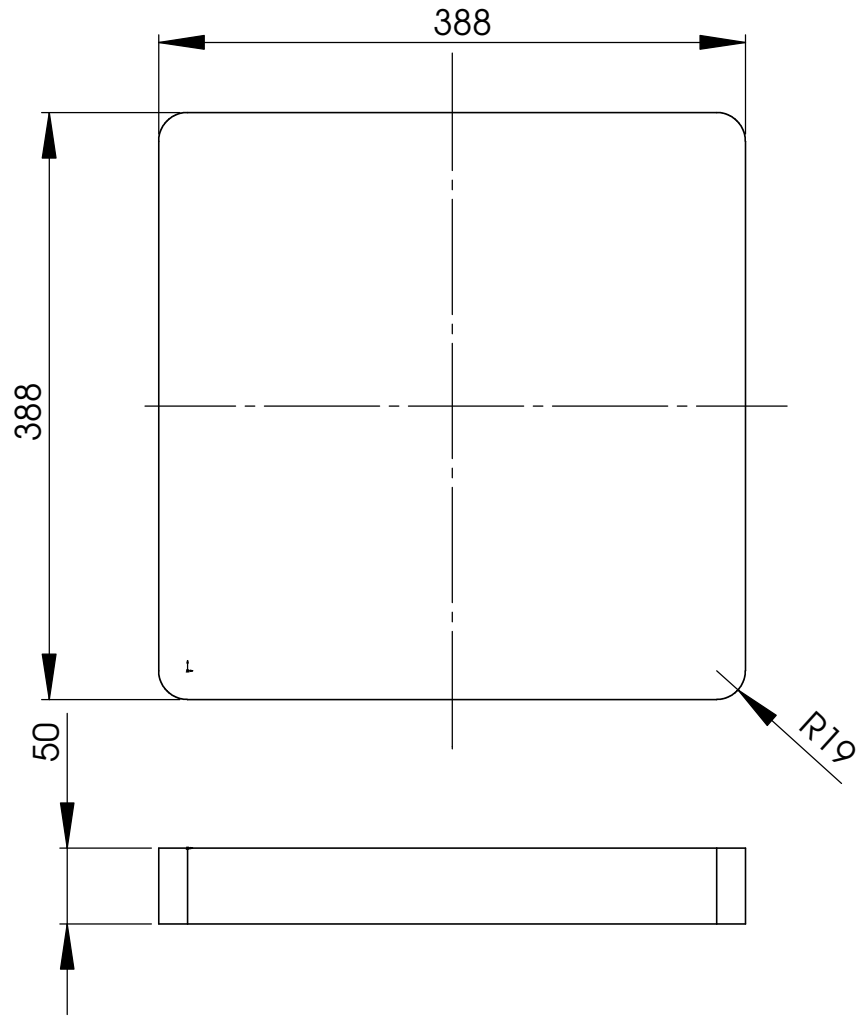

				Maßstab: 1:5		Gewicht:	
				(Werkstoff, Halbzeug)			
				Material			
				Datum		NAME	
				Gez. 22.03.2012		Autor	
				Klasse: Klasse			
				Berufliches Schulzentrum		Zeichnungsnummer:	
				Oskar-von-Miller			
				Schwandorf			
Status		Änderungen		Datum		Name	
						A4	
						Bl. 1v.1	

Benennung:
Multiplexplatte

A4

Bl. 1v.1

B

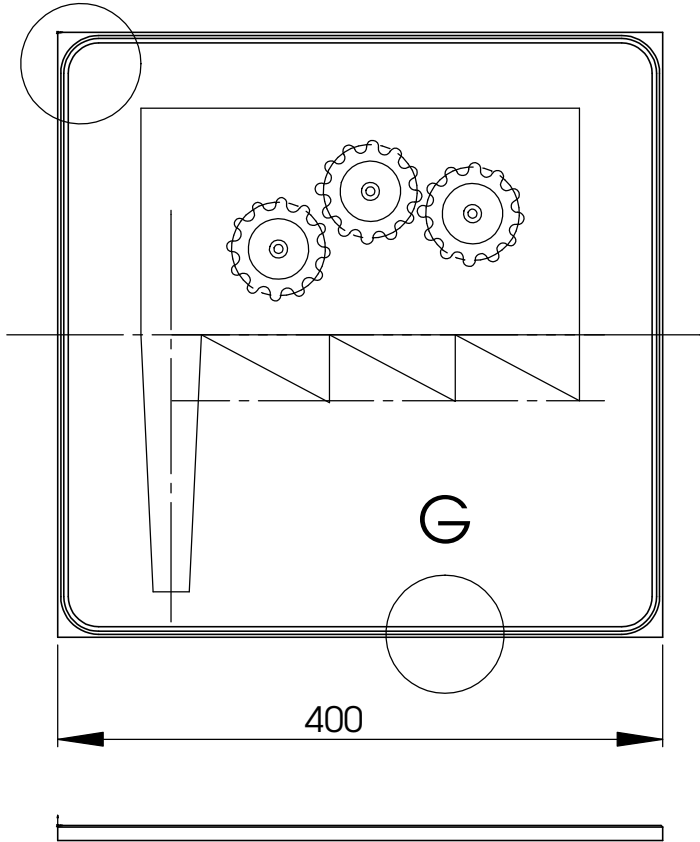

B (1 : 1)

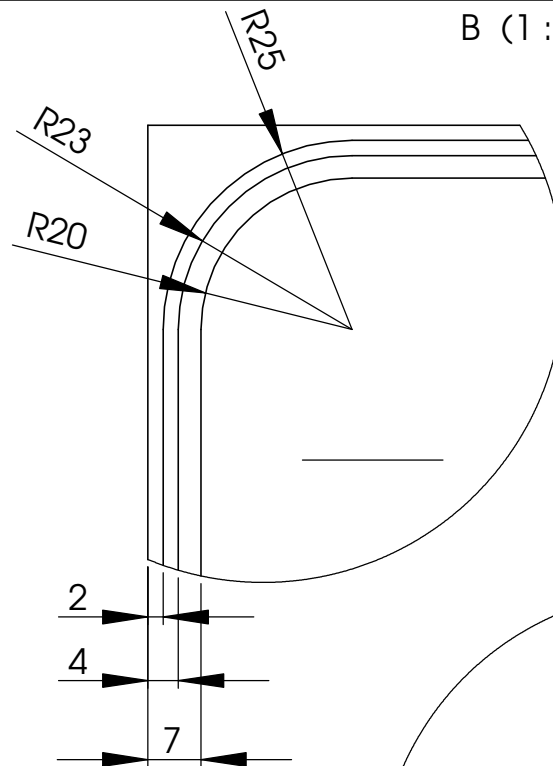

G (1 : 1)

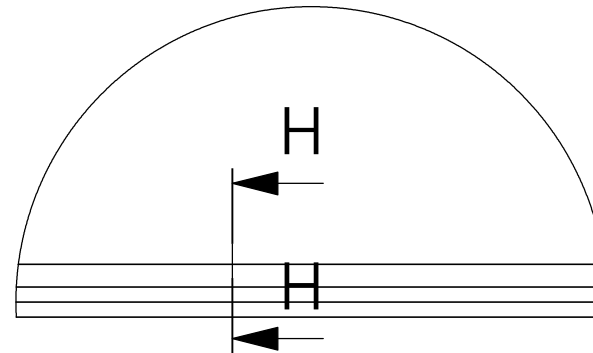

H-H (1 : 1)

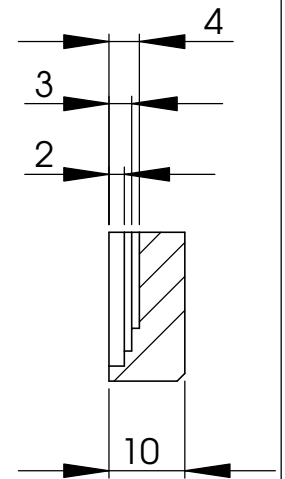

				Maßstab: 1:5		Gewicht:	
				(Werkstoff, Halbzeug)			
				Material			
				Datum		NAME	
				Gez. 22.03.2012		Autor	
				Klasse:		Klasse	
				Berufliches Schulzentrum		Zeichnungsnummer:	
				Oskar-von-Miller			
				Schwandorf			
Status		Änderungen		Datum		Name	
						A4	
						Bl. 1v.1	

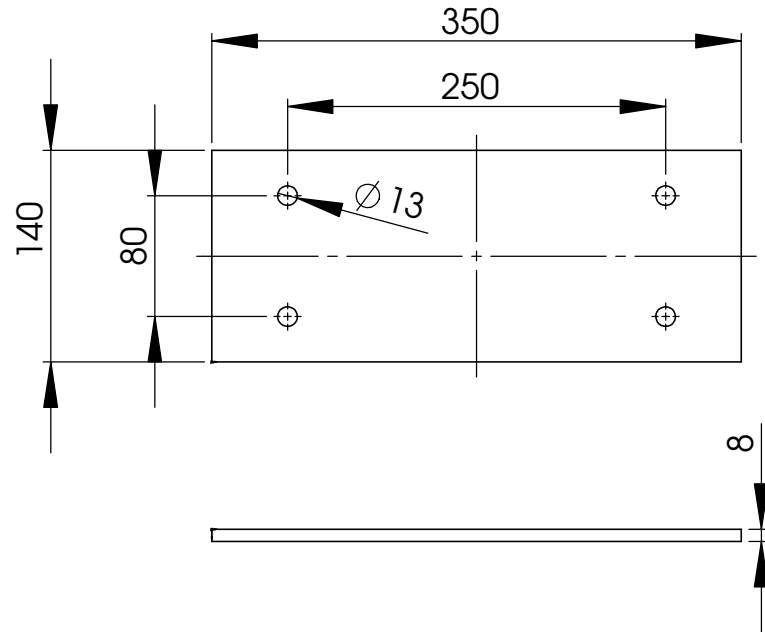

				Maßstab: 1:5		Gewicht:	
				(Werkstoff, Halbzeug)			
				Material			
				Benennung:			
				Balkenlager			
				Zeichnungsnummer:			
				A4			
				Bl. 1v.1			
				Berufliches Schulzentrum Oskar-von-Miller Schwandorf			
Status	Änderungen	Datum	Name	Gez.		Datum	
				29.03.2012		Autor	
				Klasse:		Klasse	

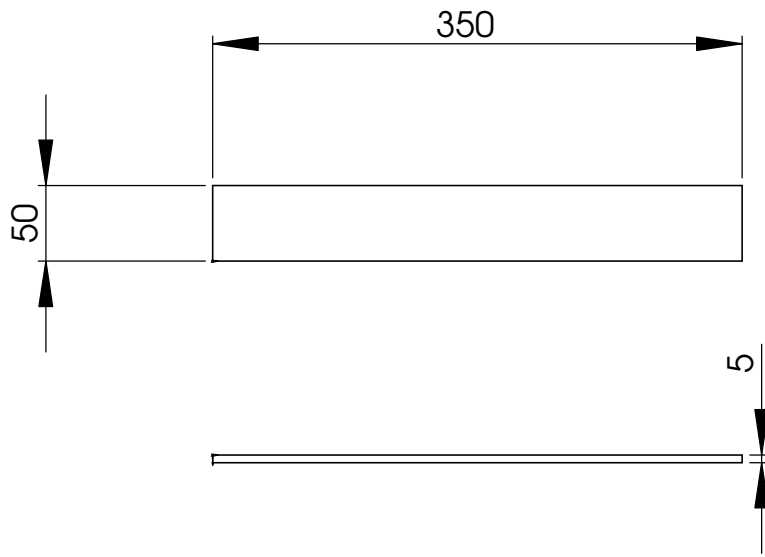

				Maßstab: 1:5		Gewicht:		
				(Werkstoff, Halbzeug)				
				Material				
				Datum	NAME	Benennung: Anker		
				Gez.	29.03.2012			Autor
				Klasse:	Klasse			
				Berufliches Schulzentrum Oskar-von-Miller Schwandorf		Zeichnungsnummer:		
						A4		
						Bl. 1v.1		
Status	Änderungen	Datum	Name					

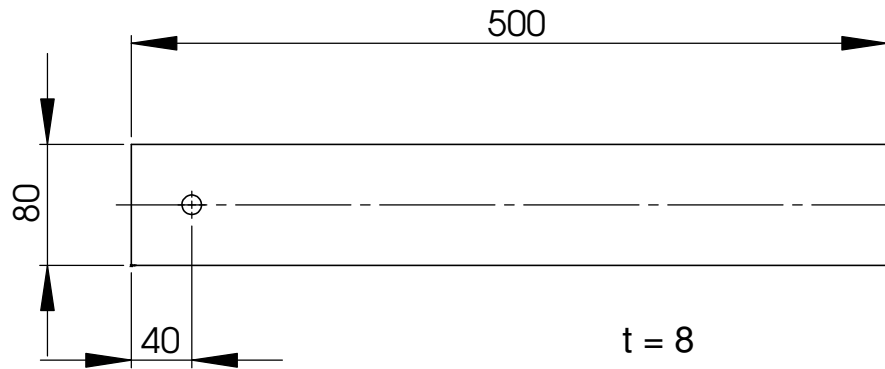

				Maßstab: 1:5		Gewicht:	
				(Werkstoff, Halbzeug)			
				Material			
				Datum	NAME	Benennung:	
				Gez. 29.03.2012	<i>Autor</i>	Anker-Wippenende	
				Klasse: Klasse			
				Berufliches Schulzentrum Oskar-von-Miller Schwandorf		Zeichnungsnummer:	
						A4	
						Bl. 1v.1	
Status	Änderungen	Datum	Name				